



Tiger Lily Products

PO Box 549
Niwot, CO, USA 80544

TLP, Blinder, Bel, Escort, Valentine

Tel 303-678-9101 Cel: 720-635-3931
Fax 303-678-9103 Cel: 720-298-0557
Email Sales@TigerLilyProducts.com
WEB www.RadarJammerTechnology.com

**Ultra-High
Performance
Electronic
Systems**

Blinder™ M20 (Dual) & M40 (Quad) Laser Jammer Installation Instructions

We recommend the customer hire a qualified technician to install the Blinder™ M20/M40 Laser Jammer.

INSTALLATION: The Blinder™ M20 should be mounted on the front of the vehicle, centered between the license plate and center of each headlight. The M40 adds two additional modules, permitting 3 laser modules in front and 1 rear, or 2 in front and 2 rear on either side of the rear license plate. Do not look directly/indirectly into the lens of the Blinder™ at close range, as it emits a bright beam of light invisible to the human eye and will cause eye damage with prolonged exposure. Install the Blinders level and horizontal with the provided level device. **Blinder™ M20 and optional M40 installation are shown at right.**

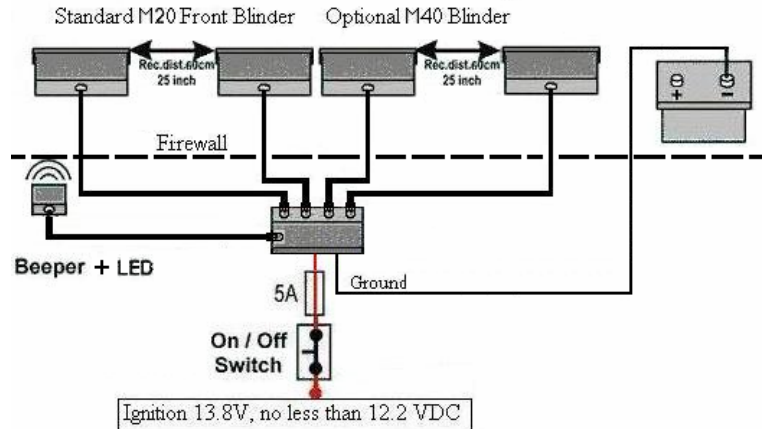

Interface Box

Locate a suitable place for the interface box inside the car's interior. The interface box must not be located in the engine compartment because of moisture. The two cables from the transceivers are plugged into two of the jacks indicated by the numbers 1 to 4.

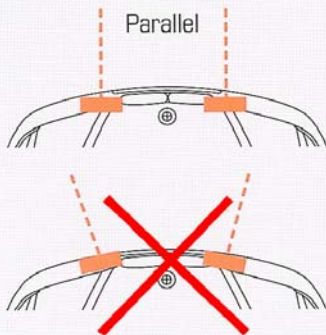

MOUNTING:

- 1) Locate the ideal horizontal location for the Blinder Module (see drawing below for 2/3/4 install in front). Try to set the modules behind the grille for best, hidden view, but do not allow any physical object in front of the curved lens.
- 2) Make sure the vehicle is parked on a level surface. Install the laser modules level and pointing straight out from the vehicle. If the grille is rounded, ensure the laser modules are pointing straight down the road and level.
- 3) Use provided hardware to fix the Blinder into position. Recheck the level of the Blinder before and after tightening to position.
- 4) Each of the Blinder Jammer modules is connected to the single interface via telephone plug in jacks. The installer will need to find a suitable thru hole in the firewall to route the M20 (2) cables or M40 (4) cables through the firewall. Each cable has a firewall grommet, permitting you to replace the present firewall grommet with the Blinder Grommet. You may need to drill a 7/16" (11mm) diameter hole in the firewall. Use the grommet provided on each cable to seal the firewall.

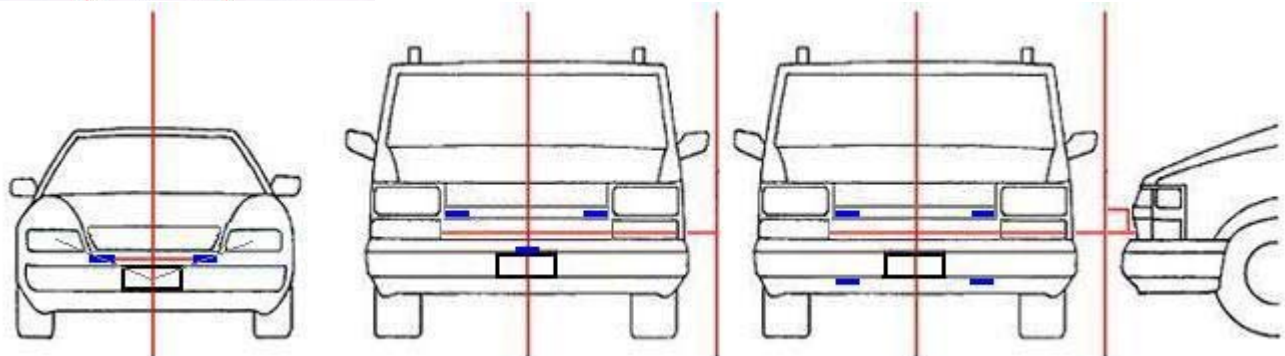

Ultra-High Performance, Prowler Remote™ Systems

PROWLER Remote, PRS1-V, PRS1-B, PRS2-V, PRS2-B, PRS3-V, PRS3-B, PRS4-E, PRS4-B, Got Performance are trademarks of Tiger Lily Products. All rights reserved. Copyright 1999-2005.

Got Performance™



Tiger Lily Products

PO Box 549
Niwot, CO, USA 80544

TLP, Blinder, Bel, Escort, Valentine

Tel 303-678-9101 Cel: 720-635-3931
Fax 303-678-9103 Cel: 720-298-0557
Email Sales@TigerLilyProducts.com
WEB www.RadarJammerTechnology.com

Ultra-High
Performance
Electronic
Systems

- 5) Ensure cables are routed with existing cable bundles and tie wrap the Blinder cables in position. Ensure no contact across hot surfaces. Connect red lead, to a spare 12Vdc connection in Ignition fuse box. Connect Fuse and Master Power On/off as shown using hardware provided in box. Connect ground black lead of interface module to vehicle ground inside the cab.
- 6) Plug Buzzer and LED Alert into appropriate Alert phone plug of the interface module and connect the Buzzer/LED at a location that suits your driving habits (perhaps above the windshield visor or in the dash).
- 7) Once proper install & electrical hookup is completed, turn Blinder power on. The Blinder™ will go through self test, & beep once for about 2 second to indicate it is in active search mode. The LED will be green with power on.

CUSTOMER MAINTENANCE: The Blinder™ M20 & M40 lens should be cleaned with a clean, soft cotton fabric as often as required to remove dust, mud, etc. Performance is degraded if the lens is muddy or covered by heavy dust. If the lens receives rock damage, call for replacement lens, which costs \$5.00 each. Replace the lens every 12 months or so.

OPERATION: When the Blinder™ M20 & M40 is turned on, it will go through a self test cycle and beep once for about 2 seconds to let the driver know it is fully functional and in active mode of operation. When the Blinder™ detects laser, it will immediately analyze the laser gun signal and jam it before the laser gun can display your speed. The Blinder will provide an audio alert to the buzzer and the LED will change from green to red. When alerted, the driver should safely check their speed over a period of 3 seconds, and then shut jamming power off after your speed has been safely adjusted. This will allow the laser gun to detect your speed after you have adjusted your speed. After driving through the laser trap, turn the Blinder™ back on, and continue your journey safely. Drive alert! Drive smart! Drive safe!

DISCLAIMER: The customer is 100% responsible for his/her driving habits under any/all situations when using the Blinder™. Damage to property or person due to negligence of any person(s) using the Blinder™ is not the responsibility of Tiger Lily Products or its certified Distributors. Tiger Lily Products, nor any of its Distributors condone speeding or unsafe driving.

Warranty: The Blinder™ M20 Dual & M40 Quad Laser Jammer is warranted against defects in material/workmanship for 12 months from purchase date, but does not include road damage caused by rock damage, improper install, incorrect wiring, misuse, wear, etc.



Ultra-High Performance, Prowler Remote™ Systems

PROWLER Remote, PRS1-V, PRS1-B, PRS2-V, PRS2-B, PRS3-V, PRS3-B, PRS4-E, PRS4-B, Got Performance are trademarks of Tiger Lily Products. All rights reserved. Copyright 1999-2005.

Got Performance™