



**Tiger Lily Products**

PO Box 549  
Niwot, CO, USA 80544

**TLP, Blinder, Bel, Escort, Valentine**

Tel 303-678-9101 Cel: 720-635-3931  
Fax 303-678-9103 Cel: 720-298-0557  
Email F.John.Turner@TigerLilyProducts.com  
WWW.1-Radar-Laser-Jammers-Detectors.com

**Ultra-High  
Performance  
Electronic  
Systems**

**VF1, VF2 and VF2 Euro Photo Speed Trap Jammer  
Installation Instructions  
To Be Installed by Professional Installation Shop**



**INSTALLATION:** The VF1 flash unit is mounted on the license plate of the motorcycle. The VF2 is mounted to the license plate(s) of a vehicle. The VF2 Euro is designed to install under the bumper of European style vehicles or directly to the bumper. The flash unit will detect the camera flash and flash the license plate with brilliant white light for a very brief instant of time. This causes the image of the plate to become over exposed with bright white light; thus, preventing the camera from acquiring an image. The bright flash is downward



across the plate and is not directed behind or in front of the vehicle. Therefore, a driver in front or behind the flash is not in the path of the bright light. No ticket in the mail! **Do not look into the flash directly, as it is very bright, and may cause eye damage.**

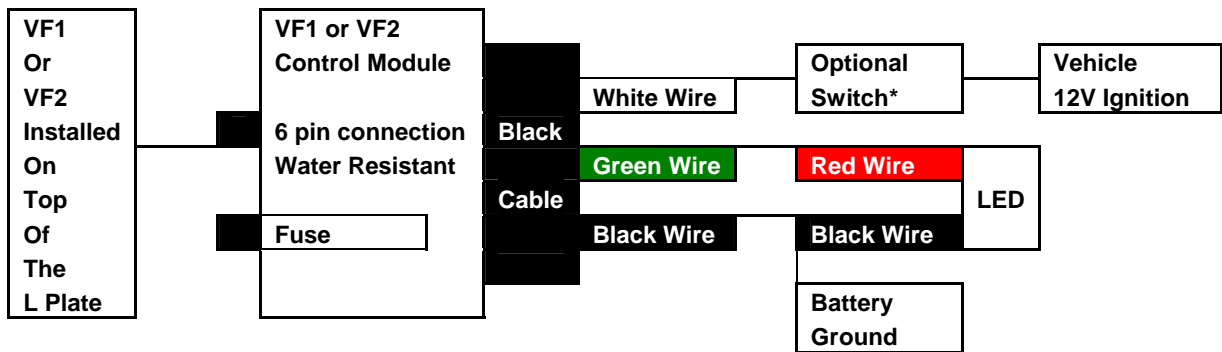

**VF1 & VF2 Photo Jammer Electrical Diagram** **Important: Disconnect Battery Before Installation.**

\* Optional On/Off switch can be purchased at a local Radio Shack shop

**Warranty requires a Professional Installer to install the VF1, VF2 or VF2 Euro products. If the product was deemed installed incorrectly, and customer can not show a professional installation by a certified shop, the VF product warranty will be invalidated.**

**MOUNTING:**

- 1) The flash unit has through holes that permit the VF product to bolt directly to the license plate mounts or bumper.
- 2) Remove the screws of the license plate and mount the VF1, VF2 and VF2 Euro plate to the top of the plate mounts. Place the License Plate over the VF base plate, such that the flash unit is behind the license plate, with the flash unit protruding over the top of the plate and facing downwards.
- 3) Using the screws that held the license plate in place, reinsert the screws through the plate holes at top and through the back plate, holding both the plate and VF tight to the license plate mounts. If installing the VF2 Euro, it has a 90 degree flange on left and right side, permitting the VF2 Euro to bolt under a bumper or directly back against a bumper. Ensure the screws can not vibrate

**Ultra-High Performance, Prowler Remote™ Systems**

PROWLER Remote, PRS1-V, PRS1-B, PRS2-V, PRS2-B, PRS3-V, PRS3-B, PRS4-E, PRS4-B, Got Performance are trademarks of Tiger Lily Products. All rights reserved. Copyright 1999-2005.

**Got Performance™**



## Tiger Lily Products

PO Box 549  
Niwot, CO, USA 80544

## TLP, Blinder, Bel, Escort, Valentine

Tel 303-678-9101 Cel: 720-635-3931  
Fax 303-678-9103 Cel: 720-298-0557  
Email [F.John.Turner@TigerLilyProducts.com](mailto:F.John.Turner@TigerLilyProducts.com)  
[WWW.1-Radar-Laser-Jammers-Detectors.com](http://WWW.1-Radar-Laser-Jammers-Detectors.com)

**Ultra-High  
Performance  
Electronic  
Systems**

loose. **If the VF product falls off the license plate mount, it would not function properly, nor be covered by warranty.**

- 4) Route the 6 pin wire of the VF flash module to the control box & ensure the cable is held firmly along an existing wire cable where possible.
- 5) Mount the control module under the motorcycle seat, or in the engine bay, up where it is kept away from rain. Plug the 6 pin cable into the control module. The cable connection is water resistant and is screwed together. Ensure the pins mate properly before screwing together.
- 6) Route the 3 wire black cable of the control module, as follows: 3 wires (White to 12 VDC ignition; connect white lead to ignition post, such that the system turns on only when ignition is turned on. **Do not connect the white wire directly to the positive side of the battery.** Connect optional On/Off switch between 12V Ignition and white wire. Ensure fuse has been inserted into power supply.
- 7) Locate the LED at a location you desire in the cab cockpit. Connect the black wire of the LED to ground. Solder or connect the red wire of the LED to the green wire of the Control Module cable. You may need to extend the LED leads based on your installation.
- 8) Once proper installed by a professional shop & electrical hookup is completed, reconnect the battery. The VF1, VF2 and VF2 Euro will turn on when the ignition is turned on. The red LED will light briefly when the ignition is first turned on, and blink briefly every time a photo trap is encountered. The VF1, VF2 and VF2 Euro will shut off when ignition is turned off. You can test the product with a digital flash camera with the RED EYE adjustment of the camera turned off. **Do not look directly up into the flash during your test.**

**9) The VF2 and VF1 circuitry has high voltage. Before disconnecting the 12Vdc lead, allow 15 minutes to discharge.**

**CUSTOMER MAINTENANCE:** The VF1, VF2 and VF2 Euro should be checked weekly for tight screws holding the photo product in place on the license plate mounts. Tiger Lily Products is not responsible for rock damage, vibration damage or improper installation to the VF1, VF2 and VF2 Euro.

**OPERATION:** When the VF1, VF2 and VF2 Euro are turned on, it is in active search mode and constantly searches for a bright camera flash or infrared flash. Once this occurs, the VF1, VF2 and VF2 Euro will respond instantly by super exposing your license plate with a bright light, causing any camera to image only a bright light. You might consider purchasing an Escort 8500 X50 or a V1 Remote Radar detector to provide advance warning while you are driving. Neither the VF1, VF2, nor the VF2 Euro will give you advance notice of a photo trap, but will jam any photo camera attempting to acquire your license photo at that instant in time. Drive smart! Drive safe! You are responsible for your driving actions.

**DISCLAIMER:** The customer is 100% responsible for his/her driving habits under any and all situations when using the VF1, VF2 and VF2 Euro. Damage to property or person due to negligence of any person(s) using the VF1, VF2 and VF2 Euro is not the responsibility of Tiger Lily Products. Tiger Lily Products, nor its certified Distributors, condones speeding or unsafe driving.

**WARRANTY:** The VF1, VF2 and VF2 Euro are warranted against defects in material/workmanship for 12 months from purchase date, if it was installed by a professional, electrical certified shop, but does not include damage caused by rocks, improper installation, non-professional installation, incorrect wiring, misuse, illegal use, wear, vibration from vehicle, etc.

**Ultra-High Performance, Prowler Remote™ Systems**

PROWLER Remote, PRS1-V, PRS1-B, PRS2-V, PRS2-B, PRS3-V, PRS3-B, PRS4-E, PRS4-B, Got Performance are trademarks of Tiger Lily Products. All rights reserved. Copyright 1999-2005.

**Got Performance™**